

COMBO Multi-Touch Panel PC Series

Compact and Projective Capacitive Touch Panel PC with Wide Temperature and Voltage Support Powered by NXP i.MX 6 Series Family

In IPC market, a robust and highly reliable Panel PC system is a must to ensure non-stop and stable operation on production line. Featuring cost effective and power efficiency, COMBO Series is an ideal HMI in factory automation, food and beverage industry, data collecting equipment environments.

Product Introduction

yocto
PROJECT



COMBO Series Panel PC is a new era and innovation of Portwell's standard Panel PC product line. Powered by Freescale™ i.MX6 processor, the cost effective and power efficient Panel PC comes with one Gigabit Ethernet, two USB 2.0 hosts, one OTG, one HDMI port, one serial port, one CAN port, a wide range DC input from DC 12V to 24V and an optional Wi-Fi/3G/4G LTE feature. Besides, it is equipped with 512MB or 2GB DDR3 memory down and 4GB/8GB eMMC, which targets to support mission-critical industrial applications.

COMBO Panel PC can boot from the onboard eMMC or SD card to Yocto Linux 3.10.53 kernel version or Android 5.0 operating systems via U-Boot boot loader, specially customized to take full advantage of the i.MX6 CPU 3D graphics acceleration capabilities. To sum up, COMBO Series Panel PC is a ready platform for all kind of industrial applications, including factory automation, machine automation, data collecting and energy-saving control systems.

Panel PC with NXP i.MX 6 Solo/Quad-core Processor

The i.MX 6 series processors unleash a scalable multi-core platform that includes single-, dual- and quad-core families based on the ARM® Cortex™ A9 architecture for next generation industrial applications. By combining the power-efficient processing capabilities with bleeding edge 3D and 2D graphics, as well as high-definition video, the i.MX 6 series provides a new level of multimedia performance to enable an unbounded next generation user experience. The unprecedented levels of performance and power efficiency making it an ideal solution for designs requiring high performance in low power or thermally constrained cost-sensitive devices.



NXP freescale
Enabled

CAN Bus Connectivity

COMBO Panel PC features CAN Bus specification version 2.0B, which supports both standard and extended message frames communication, making it a suitable equipment for applications such as cars, trucks, tractors, trains, agricultural machinery, textile machinery, etc. With a high degree of reliability and stability, CAN Bus is also widely used in industrial control.

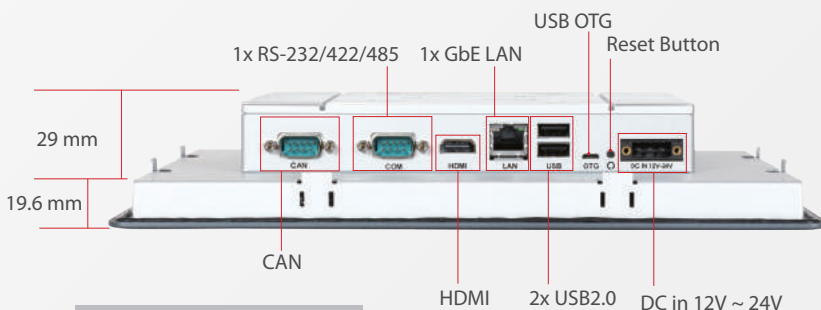

* The picture of COMBO-S1020

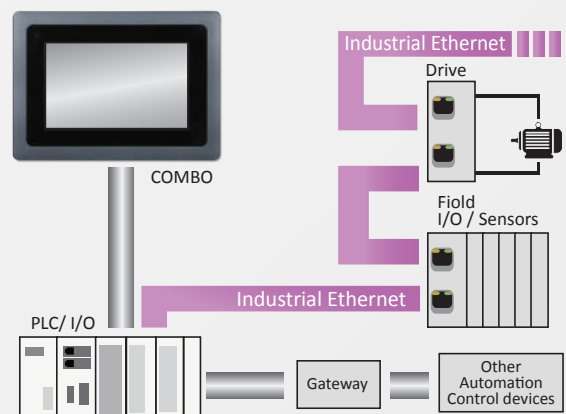



Wide Operating Temperature Support with Fan-less Design

COMBO Panel PC takes advantage of NXP i.MX6 family to operate under extremely hot and cold conditions. Compared to most Panel PC in the market, the operating temperature of COMBO Panel PC can be as low as -20°C or up to 60°C in spite of its fan-less design. Moreover, the cable-less structure optimizes the thermal dissipation as well as makes it more durable in rugged environments.

Projective Capacitive Multi-Touch Screen

By adopting antiscratch surface with 7H hardness protection, high touch durability and long-term stability are built-in features of COMBO Panel PC. 10-points multi-touch supports a full set of gestures such as zooming in/out, panning, or rotating, giving users a whole new way to control and interact with what's on the screen even with surgical gloves or thin cotton gloves.

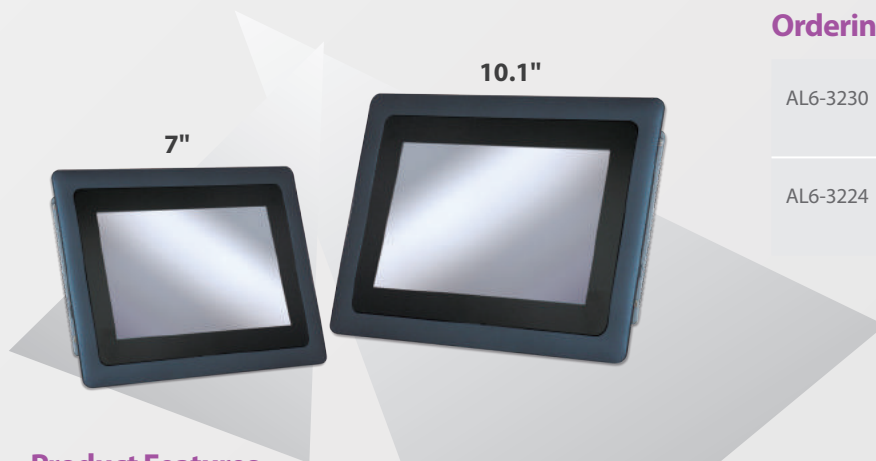
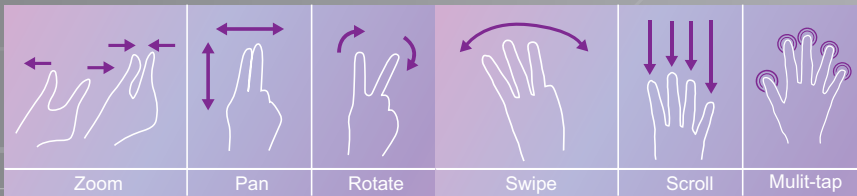

Ordering Guide

AL6-3230	(R).ATO.COMBO-S0720-PP1000. 7" NXP i.MX 6 (Cortex A9) P-CAP Panel PC
AL6-3224	(R).ATO.COMBO-S1020-PP1000. 10.1" NXP i.MX 6 (Cortex A9) P-CAP Panel PC

Product Features

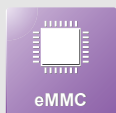
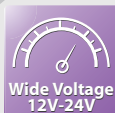

Quick Selection Guide

COMBO Multi-Touch 7" / 10.1"

Model Name	COMBO-S0720	COMBO-S1020
Display		
LCD Size	7" (16:9)	10.1" (16:9)
Resolution	WVGA 800 x 480	WXGA 1280 x 800
Brightness	300 cd/m ²	300 cd/m ²
Contrast Ratio	500 : 1	1300 : 1
Backlight	LED type	LED type
Touch Screen	Projected Capacitive Multi-Touch	
System		
SoC	Freescale™ i.MX6 Solo/Quad-core Processor (Coretex™ A9)	
Memory	512MB/2GB DDR3 1066 Memory Chip on Board	
BIOS	N/A	
Graphics	Freescale™ i.MX6 Graphic Engine	
LVDS	Single/Dual Channel 24-bit	
LAN Chipset	Single Atheros AR8035 Ethernet PHY	
Audio	Wolfson WM8962 Audio Codec	
Watchdog Timer	Control by Software	
Storage Device	4/8GB eMMC on board, 1 x SD card	
OS	Linux™ 3.10.53 + QT 5.2 / Android 5.0	
I/O Interface		
Series Port	1 x RS-232/422/485	
Display	1 x HDMI	
USB	2 x USB 2.0, 1 x USB OTG	
Ethernet	1 x Gigabit Ethernet	
Others	1 x CAN 2.0B (DB9) 1 x SMA Antenna hole for WiFi, 3G, 4G LTE Solution	
Expansion	1x Full-size Mini-PCIe socket 1 x DVI-D input, 4-bit DI / 4-bit DO, 1 x RS-232 (Optional)	
Mechanical		
Dimesion(mm)(WxDxH)	217 x 156 x 45.9 mm	286 x 196 x 48.6 mm
Mounting	VESA Mount 50 x 25, 75 x 75 ; Panel Mount	
Weight (Kg)(N)	1.2 Kg	1.6 Kg
Weight (Kg)(G)	3 Kg	3.4 Kg
Power		
Power Supply	DC 12V ~ 24V input with 3-pin terminal block connector	
Consumption (Max)	23 W	25 W
Consumption (Min)	4.8 W	6.2 W
Environmental		
OP /Storage Temp	-20 ~ 60 °C / -30 ~ 80°C (20 ~ 90% non-condensing)	
Vibration	1.0G (SD/eMMC), Power on & 2.16G, Packaged; 5~500Hz, IEC 60068-2-6	
Shock	15G peak acceleration, 11 ms (Power on condition), IEC 60068-2-27	
Drop	Package with Carton from 96.5 cm (1-Corner, 3-Axis, 6-Face), ISTA 2A Standard	
IP Protection	IP65 (Front) / IP20 (Rear), IEC 60529 Edition 2.1 Standard	
Certificate	CE/FCC Class A	

Cut out Dimension

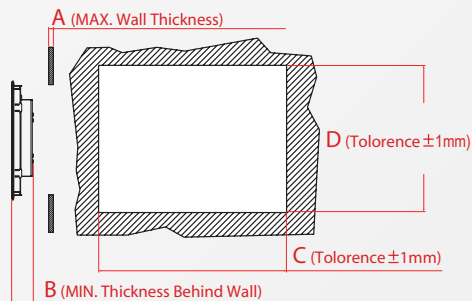

COMBO Multi-Touch

	A (mm)	B (mm)	C (mm)	D (mm)	Mounting Kits (pcs)
COMBO-S0720	< 6.5	42	201	140	x 8
COMBO-S1020	< 8.6	45	270	180	x 8