

CS181-Q370 Desktop

9th/8th Gen Intel® Core™
Mini-ITX

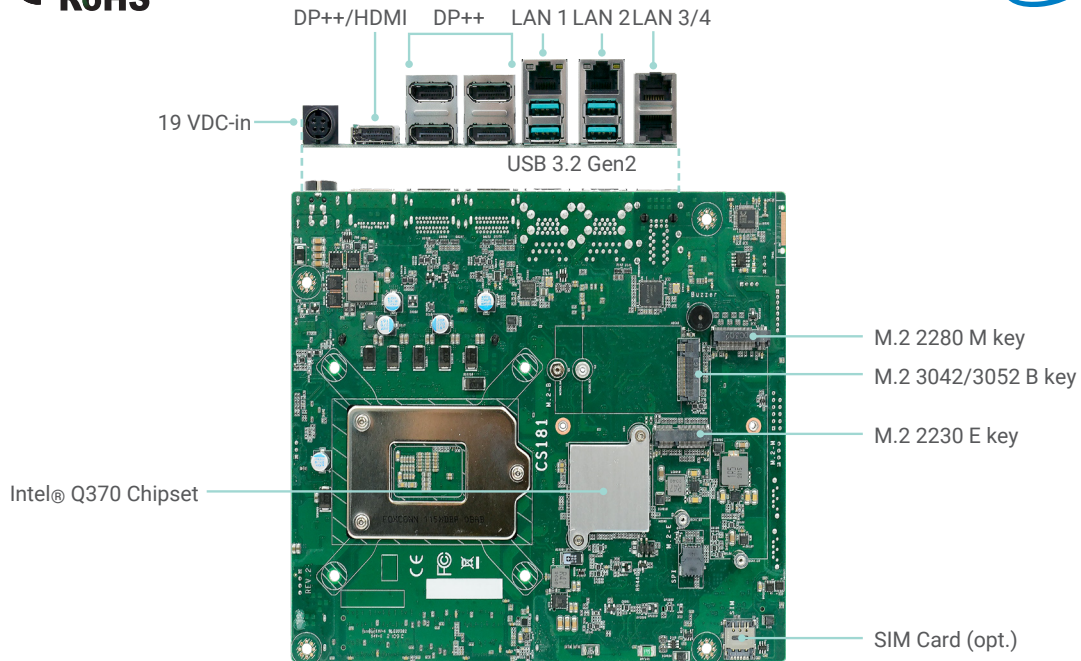

Bottom View

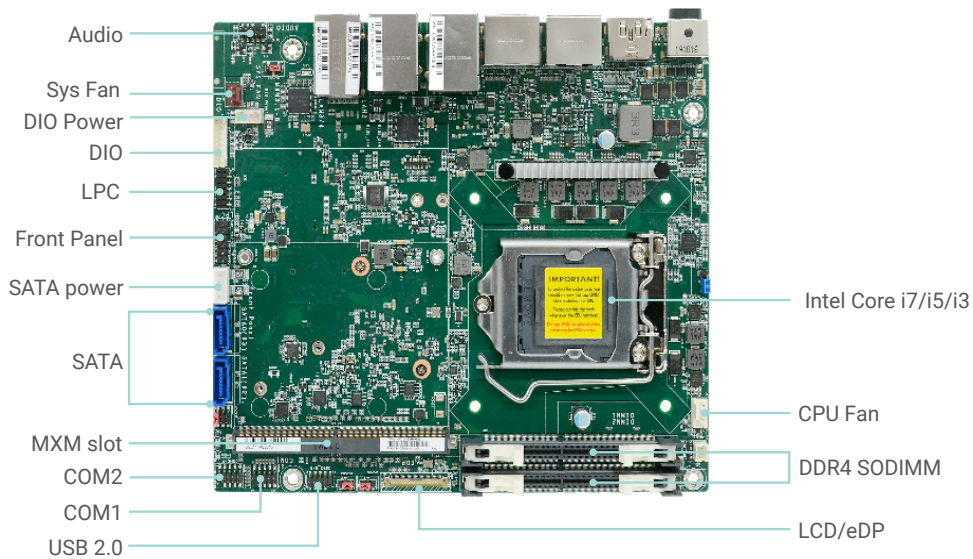

Top View

KEY FEATURES



DDR4

2 DDR4 SODIMM up to 64GB



4K High Resolution

Supports 4K/ 2K resolution



Multiple Displays

1 eDP ,
1 DP++/HDMI (auto-detection)
4 DP



Multiple Expansion

1 MXM Type-A/B/B+/C,
1 M.2 M Key,
1 M.2 B Key,
1 M.2 E Key



Rich I/O

4 Intel GbE, 2 COM,
4 USB 3.2 Gen2,
2 USB 2.0

BLOCK DIAGRAM

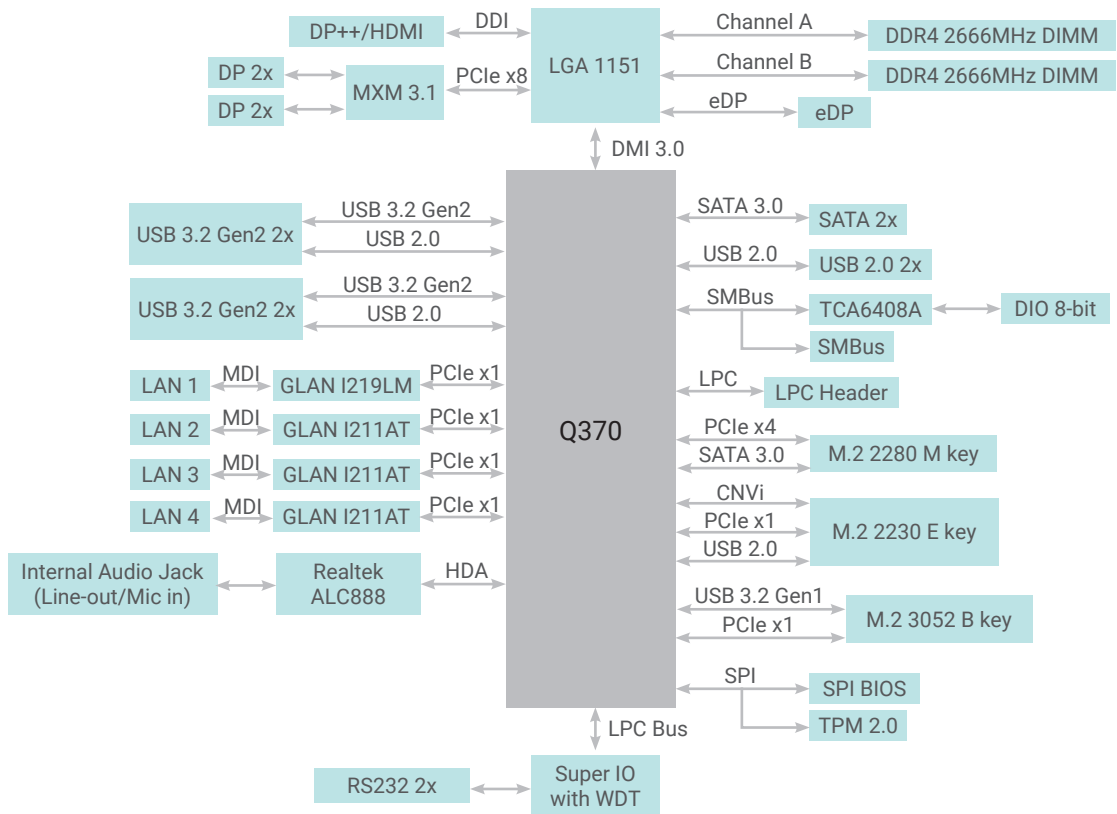

MECHANICAL DRAWING

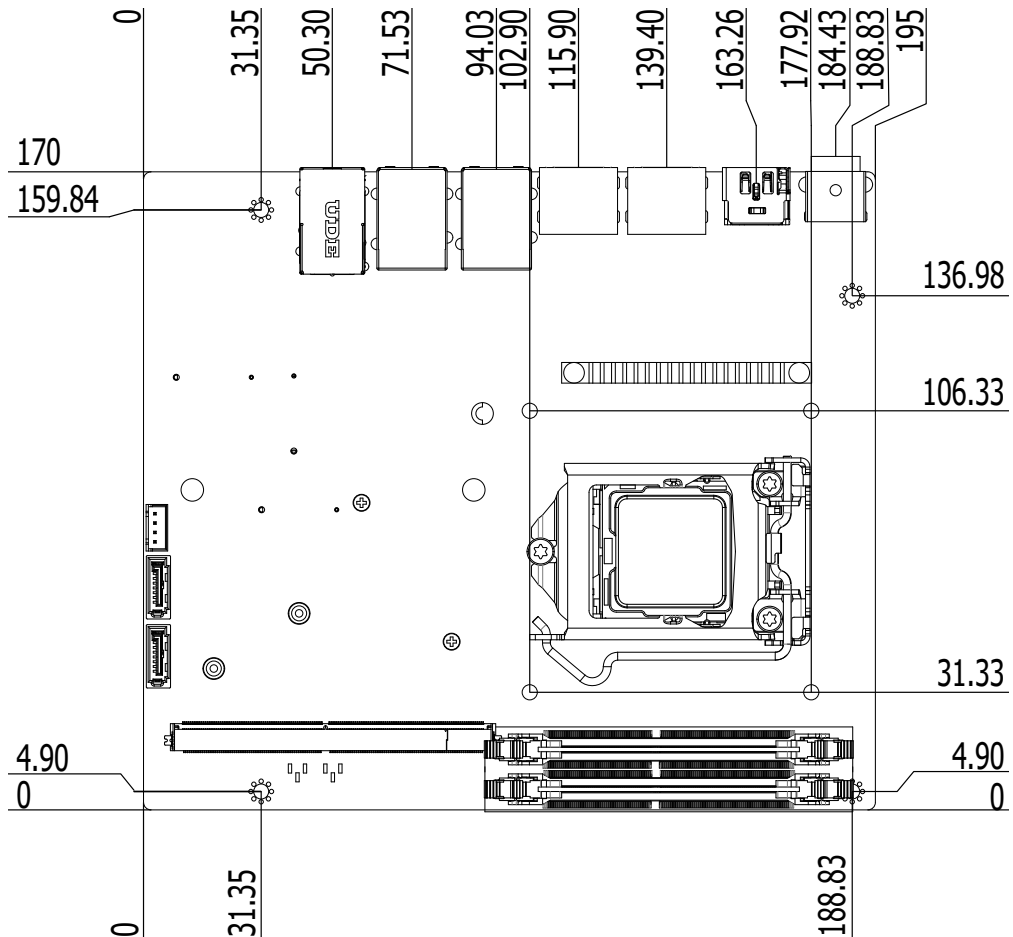

SPECIFICATION

System	Processor	9th Generation Intel® Core™ Processors, LGA 1151 Socket, TDP up to 65W Intel® Core i7-9700E Processor (Core 8; Max speed 4.4 GHz; TDP 65W) Intel® Core i7-9700TE Processor (Core 8; Max speed 3.8 GHz; TDP 35W) Intel® Core i5-9500E Processor (Core 6; Max speed 4.2 GHz; TDP 65W) Intel® Core i5-9500TE Processor (Core 6; Max speed 3.6 GHz; TDP 35W) Intel® Core i3-9100E Processor (Core 4; Max speed 3.7 GHz; TDP 65W) Intel® Core i3-9100TE Processor (Core 4; Max speed 3.2 GHz; TDP 35W) 8th Generation Intel® Core™ Processors, LGA 1151 Socket, TDP up to 65W Intel® Core™ i7-8700 Processor (Core 6; Max speed 4.6 GHz; TDP 65W) Intel® Core™ i7-8700T Processor (Core 6; Max speed 4.0 GHz; TDP 35W) Intel® Core™ i5-8500 Processor (Core 6; Max speed 4.1 GHz; TDP 65W) Intel® Core™ i5-8500T Processor (Core 6; Max speed 3.5 GHz; TDP 35W) Intel® Core™ i3-8100 Processor (Core 4; Max speed 3.6 GHz; TDP 65W) Intel® Core™ i3-8100T Processor (Core 4; Max speed 3.1 GHz; TDP 35W) Intel® Pentium G5400 Processor (Core 2; Max speed 3.7 GHz; TDP 58W) Intel® Celeron G4900 Processor (Core 2; Max speed 3.1 GHz; TDP 54W)	
	Chipset	Intel® Q370 Chipset	
	Memory	Two 260-pin SODIMM up to 64GB Dual Channel DDR4 2400/2666MHz	
	BIOS	AMI SPI 128Mbit	
	Graphics	Controller	Intel® UHD Graphics 630 (Pentium G5400 and Celeron G4900 support Intel® UHD Graphics 610)
Feature		OpenGL 4.5, DirectX 12, OpenCL 2.1 HW Decode: AVC/H.264, MPEG2, VC1/WMV9, JPEG/MJPEG, HEVC/H265, VP8, VP9 HW Encode: AVC/H.264, MPEG2, JPEG, HEVC/H265, VP8, VP9	
Display		1 x eDP 1 x DP++/HDMI (auto-detection) (located at front side) 4 x DP (support by MXM Type-A/B module) (located at rear side) eDP: resolution up to 4096x2304 @ 60Hz DP: resolution up to 4096x2304 @ 60Hz HDMI: resolution up to 4096x2160 @ 30Hz	
Multiple Displays		Onboard: eDP + DP++/HDMI Onboard+MXM module: eDP + DP++/HDMI + DP + DP + DP + DP	
Expansion		Interface	1 x MXM Type-A/B/B+/C (support MXM module) (provide 4 x independent DP at rear side), up to 150W 1 x M.2 2280 M Key (PCIe Gen3 x4/SATA 3.0)(support NVMe and Intel® Optane memory) 1 x M.2 3042/3052 B Key (PCIe Gen3 x1) (support 5G or storage module) / USB 3.2 Gen1 1 x M.2 2230 E Key (USB2.0/PCIe Gen3 x1) (support BT/Wi-Fi module)
Audio	Audio Codec	Realtek ALC888S-VD2-GR	
Ethernet	Controller	1 x Intel® I219LM PHY (10/100/1000Mbps) 3 x Intel® I211AT PCIe (10/100/1000Mbps)	
Rear I/O	Ethernet	4 x GbE (RJ-45)	
	USB	4 x USB 3.2 Gen2 (dual type-A connector)	
	Power	1 x DC Jack	
	Display	1 x DP++/HDMI (auto-detection)	
Internal I/O	Serial	2 x RS232/RS422/RS485, Select by BIOS	
	Display	1 x eDP (opt.) 1 x LCD/Inverter Power	
	Audio	1 x Front Audio (2 x 5 10-pin 2.00mm pitch header)	
	USB	2 x USB 2.0 (2 x 5 10-pin 2.00mm pitch header)	
	SATA	2 x SATA 3.0 (up to 6Gb/s) RAID 0/1/5	
	DIO	1 x 8-bit DIO (1 x 8 8-pin 2.00mm pitch header) 1 x DIO Power (1x 4 4-pin 2.00mm pitch header)	
	LPC	1 x LPC (2 x 7 14-pin 2.00mm pitch female header)	
	SMBus	1 x SMBus	
	Watchdog Timer	Output & Interval	System Reset, Programmable via Software from 1 to 255 Seconds
	Security	TPM	dTPM2.0 (default)
Power	Type	Single 19V +/-5% DC	
	Connector	DC-in Jack	
	Consumption	TBD	
	RTC Battery	CR2032 Coin Cell	
OS Support	Microsoft	Windows 10 IoT Enterprise 64-bit	
	Linux	Linux	

Environment	Temperature	Operating: -5 to 65°C Storage: -40 to 85°C
	Humidity	Operating: 5 to 90% RH Storage: 5 to 90% RH
	MTBF	TBD
Mechanism	Dimensions	195mm (7.7") x 170mm (6.7")
	Height	PCB: 1.6mm Top Side: 26mm, Bottom Side: 10mm

PACKING LIST

1 CS181 motherboard	
1 Serial ATA data with power cable (Length: 300mm)	A81-002013-000G
1 COM port cable (Length: 250mm, 1 COM port)	A81-015011-001G
1 USB port cable (Length: 200mm)	A81-001032-016G
1 Driver DVD	

OPTIONAL ITEMS

I/O shield	TBD
COM port cable (Length: 250mm, 1 COM port)	A81-015011-001G
Serial ATA data cable (Length: 500mm)	332-553001-005G
Serial ATA power cable (Length: 300mm)	A81-002044-016G
Thermal solution (For 35W, Height: 37.3mm)	A71-103004-000G
Thermal solution (For 65W, Height: 45.3mm)	A71-103005-000G
MXM Quadro P2000 (58W, 0~55°C)	612-EGXMXM-100G
MXM Quadro RTX 3000 (80W, 0~55°C)	612-M3T300-000G