

# FPM-3151G

## 15" XGA Industrial Monitor with Resistive Touchscreen, Direct-VGA, DVI Ports, and Wide Operating Temperature



### Features

- 15" XGA TFT LED LCD with 50,000 backlight life time
- Robust anodized coated aluminum front bezel and stainless steel rear cover
- Supports wide operating temperatures
- Increase reliability by enhanced 5-wire resistive touch sensor
- Anti-glare screen with tempered glass and IP65 certified front panel
- Full enclosure ground isolation protection
- Supports VGA/DVI input, dual touch interfaces and two power inputs
- Front lockable OSD membrane keys with user-defined brightness setting
- Front panel is IP65 compliant
- Supports panel, VESA, wall and desktop stand mounting

### Introduction

The FPM-3151G is an extremely rugged and reliable 15" XGA wide temperature industrial monitor for various industrial applications. Equipped with a hard anodized coating, stainless steel chassis, and -20 to 60°C operating temperature, it can satisfy demands in a wide range of harsh industrial applications. This model also features enhanced 5-wire resistive touch and system ground isolation protection to enhance the reliability. FPM-3151G also provides lockable OSD keys on the front panel with two user-defined contrast/brightness settings.

### Specifications

#### General

- **Button Controls** OSD control pad on front panel with lockable function  
Two user-defined contrast/brightness settings
- **Certification** CE, FCC Class A, BSMI, CCC, UL, Energy Star
- **Dimensions (W x H x D)** 422 x 310 x 70 mm (16.61" x 12.2" x 2.76")
- **Enclosure** Front panel: Aluminum with hard anodizing coating  
Rear cover: Stainless steel  
Ground Isolation Protection
- **Mounting** Panel, wall, desktop, VESA arm
- **Power Input** Phoenix Jack: 24 V<sub>DC</sub> input  
DC Jack: 12 V<sub>DC</sub> input
- **Power Consumption** 12W +20%
- **Video Port** VGA & DVI-D Port
- **Weight (Net)** 7.73 kg (17.04 lbs)

#### LCD Display

- **Display Type** XGA TFT LCD
- **Backlight Type** LED
- **Display Size** 15"
- **Max. Resolution** 1024 x 768
- **Max. Color** 16.2M (RGB 8-bit)
- **Viewing Angle (H/V°)** 160/140
- **Luminance (cd/m<sup>2</sup>)** 350
- **Backlight Life (hrs)** 50,000
- **Contrast Ratio** 700:1

#### Touchscreen

- **Driver** Penmount 6000
- **Type** 5-wire resistive with enhanced ITO film
- **Interface** USB & RS-232 (Combo)
- **Lifespan** 36 million with a silicone rubber R8 finger, writing rate is by 250g at 2 times/s
- **Light Transmission** > 80%
- **OS Support** Windows XP,2000,Vista,7,8/8.1,10 , XP/7/8/10 Embedded,CE,Linux
- **Power Consumption** +5 V @ 100 mA
- **Touch Resolution** Linearity

#### Environment

- **Operation Temperature** -20 ~ 60°C (-4 ~ 140°F)
- **Storage Temperature** -30 ~ 80°C (-22 ~ 176°F)
- **Humidity (Storage)** 90% @ 50°C non-condensing
- **Waterproof** Front panel is IP65 compliant
- **Shock** 11ms, 10G (Non Operating, Half Sine Wave)
- **Vibration** 5 ~ 500 Hz, 1 Grms (Operating, Random)

### Ordering Information

- **FPM-3151G-R3BE** 15" XGA Ind. Monitor w/ Wide Temp, Resistive TS

## Dimensions

Unit: mm [inch]

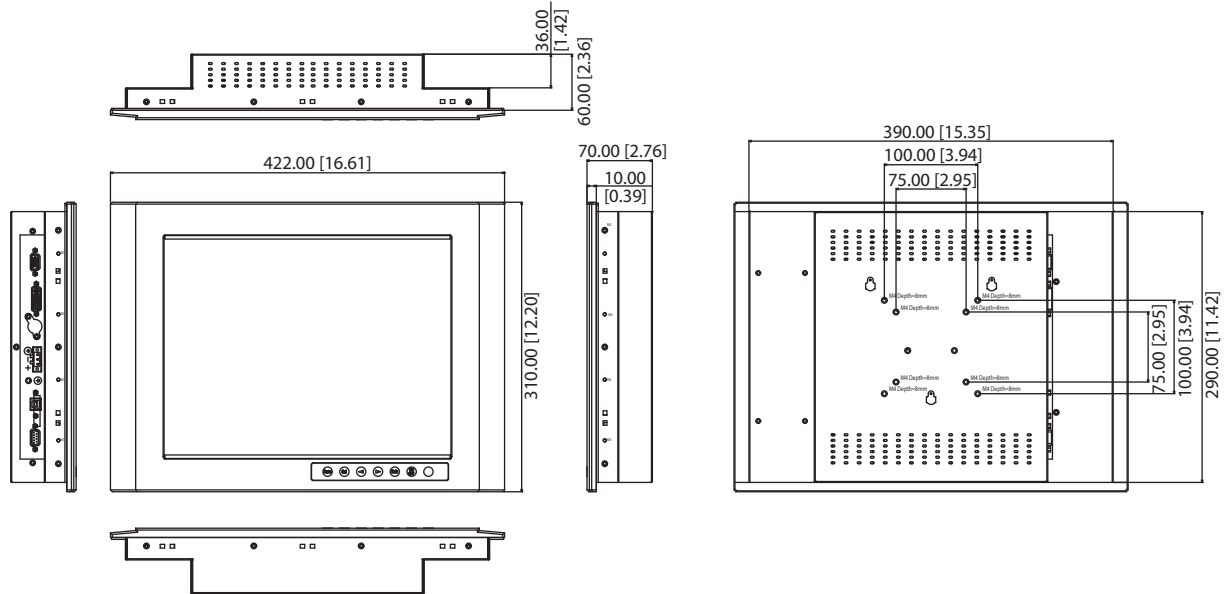

Panel Cut-out Dimensions: 392 x 292 mm(15.43" x 11.49")

## Optional Accessories

- 1702002600 Power Cable US Plug 1.8 M
- 1702002605 Power Cable EU Plug 1.8 M
- 1702031801 Power Cable UK Plug 1.8 M
- 1700000596 Power Cable China/Australia Plug 1.8 M
- FPM-1000T-SMKE Desktop/Wall Mounting kit for FPM series
- 96PSA-A60W12V1-1 Adapter 100-240V 60W 12V 5A
- 96PSA-A60W24T2 Adapter 100-240V 60W 24V 2.5A
- FPM-3001G-ADKE Adapter bracket for FPM-3000 15"/17"/19"

## Rack Mount (FPM-3151G-RMKE)



## I/O View

